

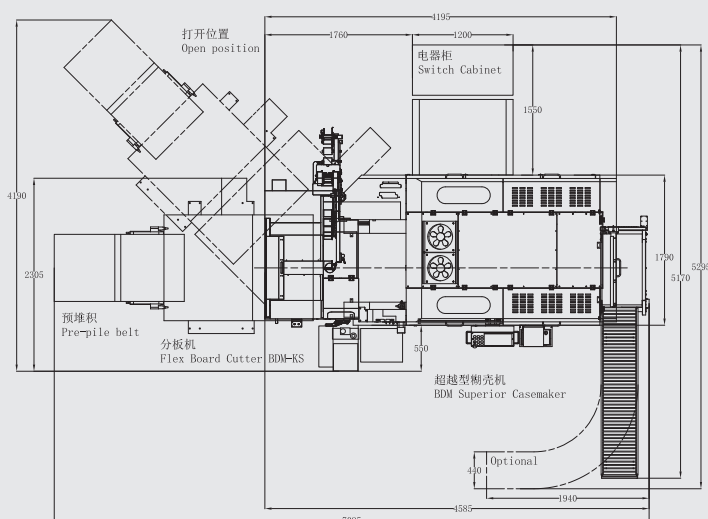

Superior Casemaker

BDM Superior

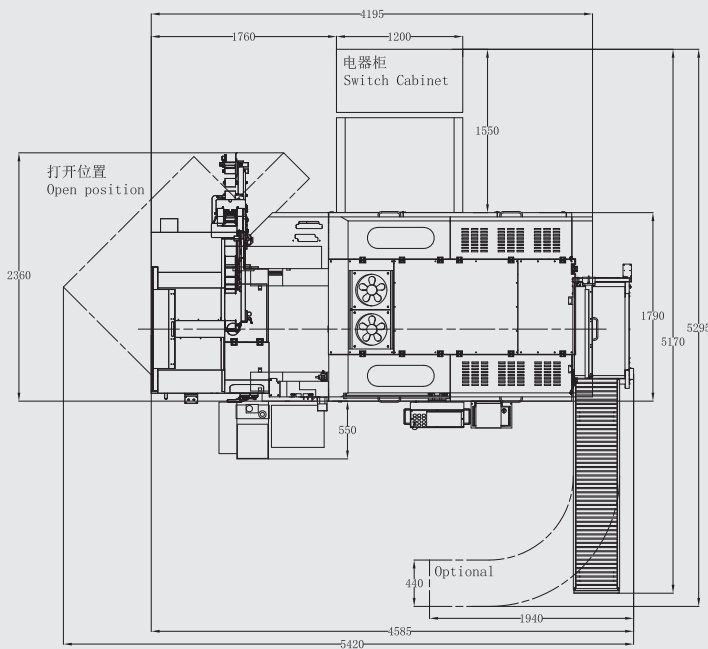

Technical Specification

Capacity:
Up to 60 cases / min.

Case size (open) :
min. : 100x150 mm
max. : 405x680 mm

Case with round corner (open) :
min. : 140x160 mm
max. : 380x630 mm

Board thickness:
min. : 1 mm
max. : 4 mm

Spine width:
min. : 6 mm
max. : 90 mm

Hinge width:
min. : 5 mm
max. : 15 mm

Distance between front and back cover:
min. : 16 mm
max. : 120 mm

Thickness of rigid spine:
min. : 1 mm
max. : 3 mm (Depends on width)

Thickness of flexible spine:
min. : 0.3 mm
max. : 0.6 mm

Thickness of cover material:
min. : 0.1 mm
max. : 0.3 mm

Power requirements:
max. : 16.5 kw
(Heating load there of 6 kw)

Compressed air requirements:
max. 1000 NI/min , at 6 bar

Weight of machine:
7100 kg

Weight of switch cabinet:
300 kg



Superior Casemaker

BDM Superior

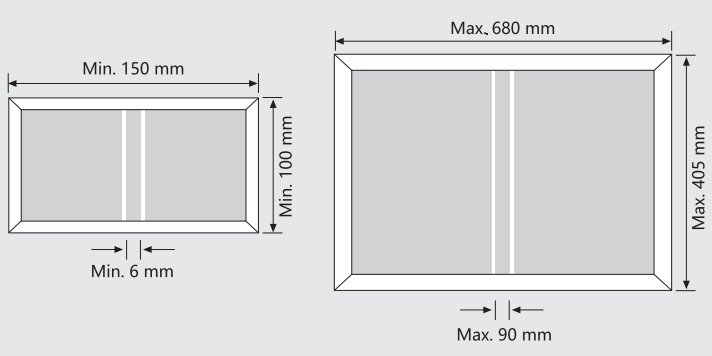
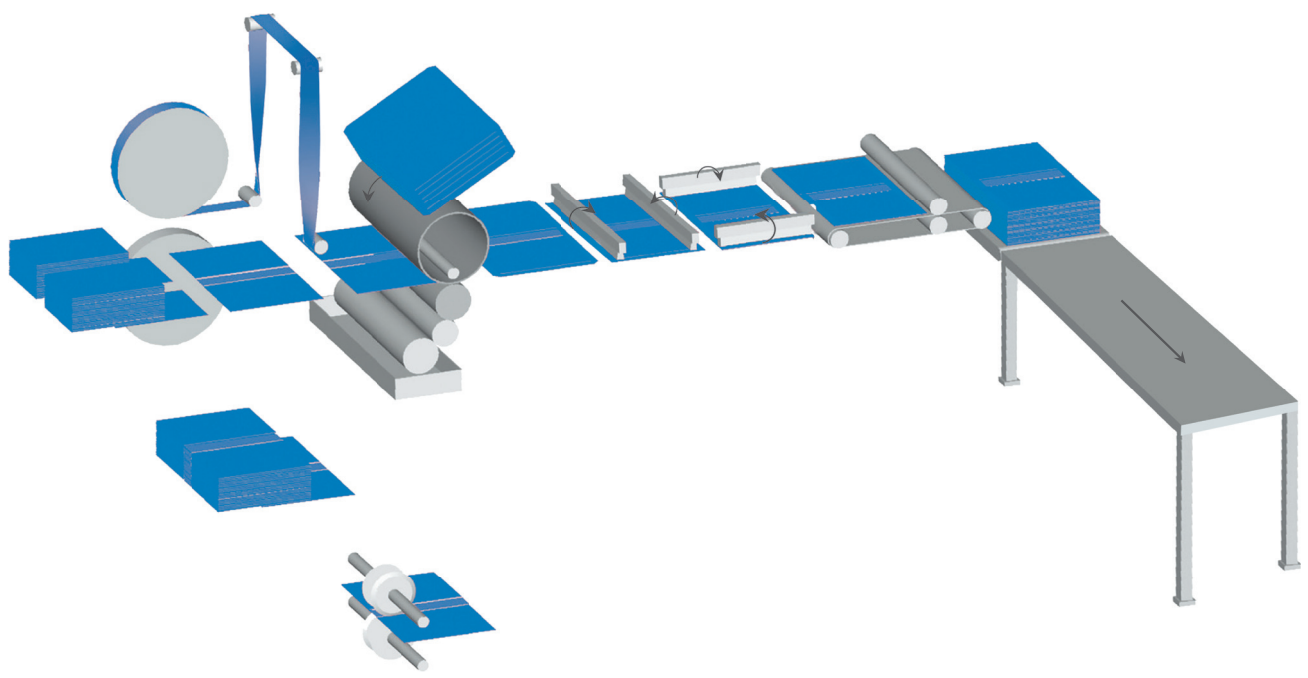

 Hoerauf (Shanghai) Machinery Co.,Ltd.
 Factory Building 7,818 Xinji Road Qingpu Industrial Zone
 Shanghai 201707,China Tel: +86 21 59700622
 E-mail:sales@horaufchina.com <http://www.horaufchina.com>