

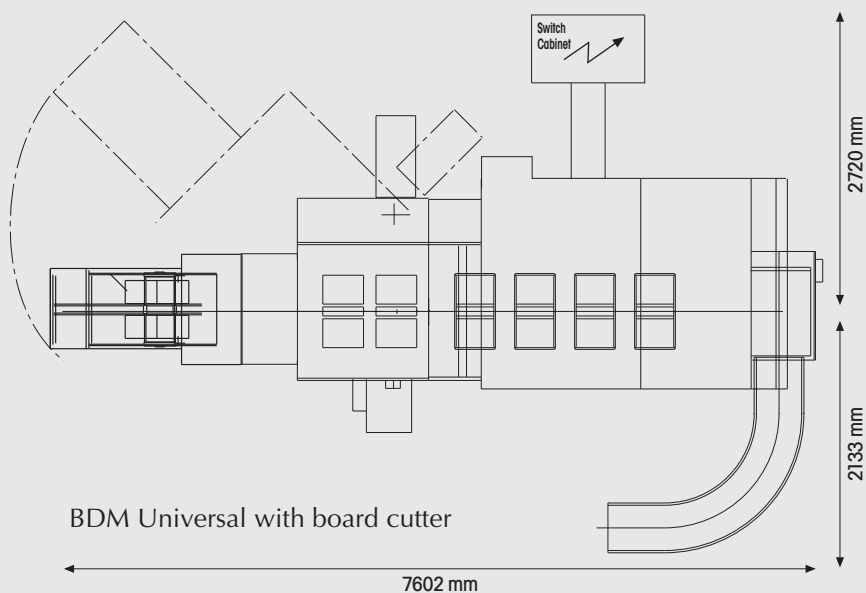

Universal Casemaker

BDM

UNIVERSAL

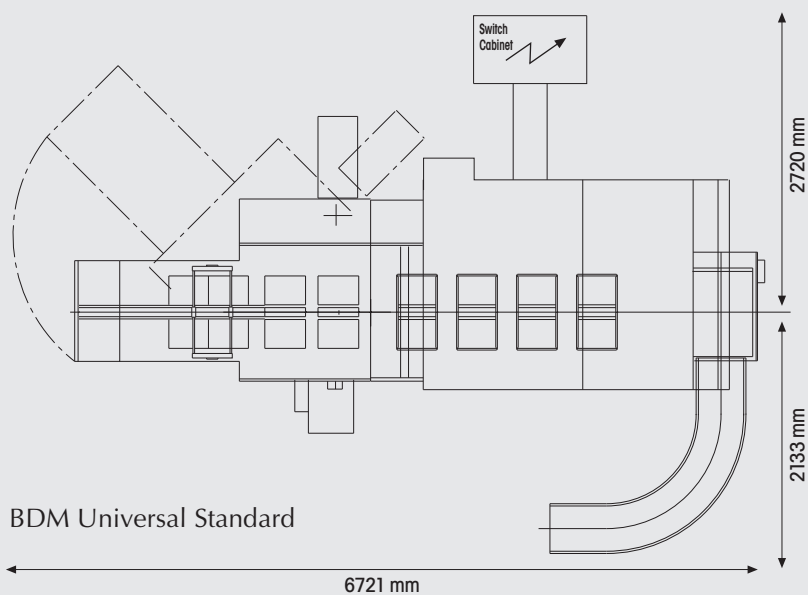

Technical Specification

Capacity:

up to 60 cases / min.

Case size (open):

min. 105 x 170 mm
max. 410 x 720 mm

Board thickness:

min. 1 mm / Option 0,6 mm
max. 4 mm

Spine width:

min. 6 mm
max. 90 mm

Boardcutter:

min. 8 mm / Option 6 mm
max. 90 mm

Hinge width:

min. 5 mm
max. 15 mm

Distance between the two boards:

min. 16 mm
max. 120 mm

Thickness of rigid spine:

min. 1 mm
max. 3 mm
depends on width

Thickness of flexible spine:

min. 0,3 mm
max. 0,6 mm

Thickness of cover material:

min. 0,1 mm
max. 0,3 mm

Power requirements:

max. 26,5 kW with board cutter
max. 25,0 kW without board cutter

Compressed air requirements:

max. 1200 NI/minute at 6 bar

Weight of machine:

approx. 8000 kg with board cutter
approx. 7000 kg without board cutter

Weight of switch cabinet:

approx. 800 kg

Michael Hörauf Maschinenfabrik GmbH & Co. KG

Mozartstraße 39 - 41 · D - 73072 Donzdorf - Germany

Phone: +49(0) 7162 / 942-0 e-mail: sales@hoerauf.com

Fax: +49(0) 7162 / 942-510 www.hoerauf.com



Universal Casemaker

BDM UNIVERSAL

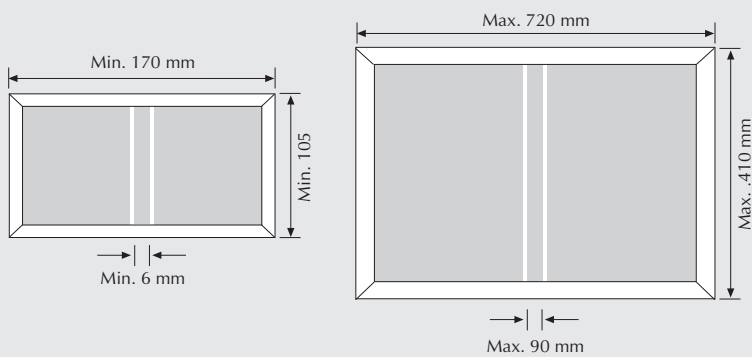
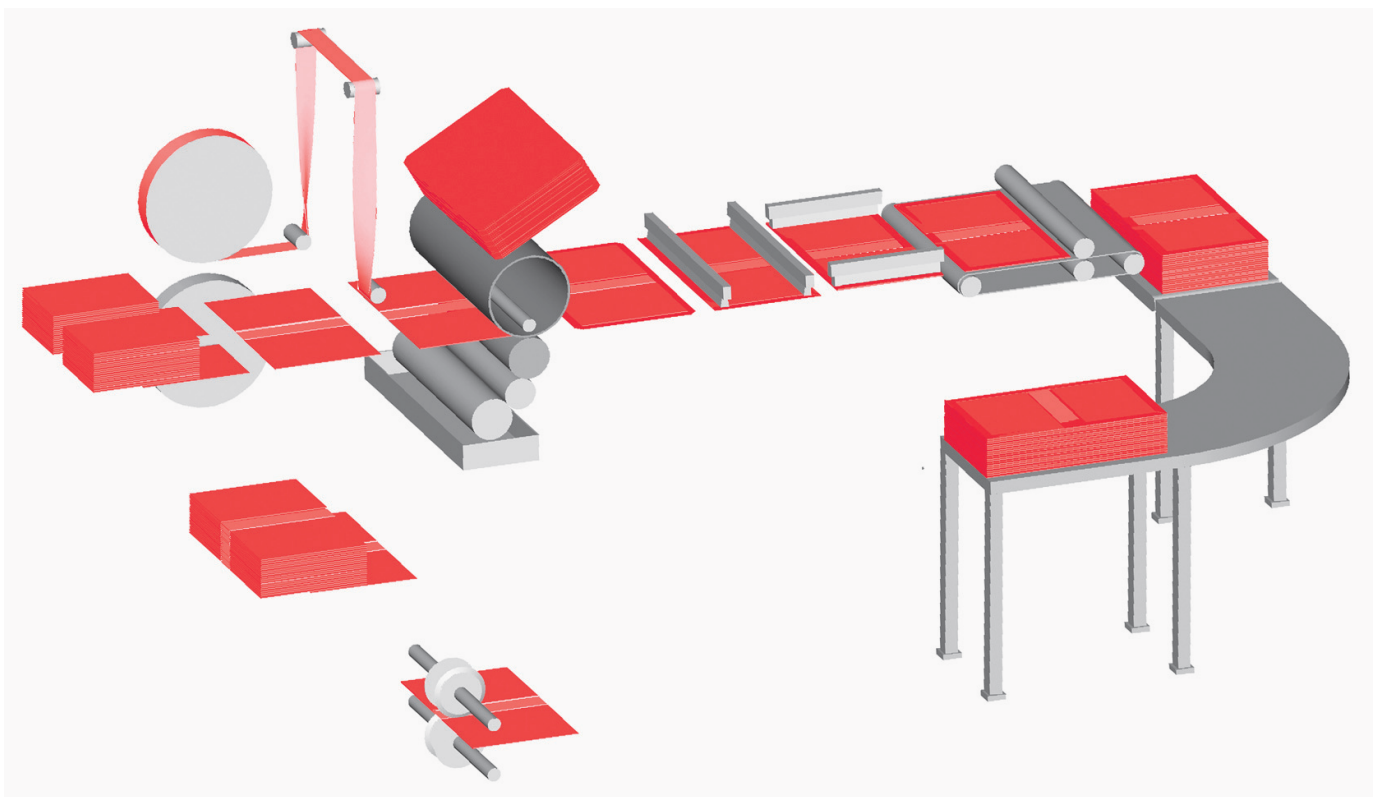

Fig. partly similar, technical changes reserved.